

DS-IRVP400F

- IR Vandal Proof Day & Night
- 1/3" SONY Super HAD CCD
- 410K
- Built in **fixed board lens** (f:6mm @ F2.0)
- CDS Auto Switching Infrared LED
- **24 Infrared LED**
- Visibility range: 15m
- Operation of degree: Panning 0°~355°, Tilting 10°~90° (Manual)
- **Vandal proof** with aluminum housing

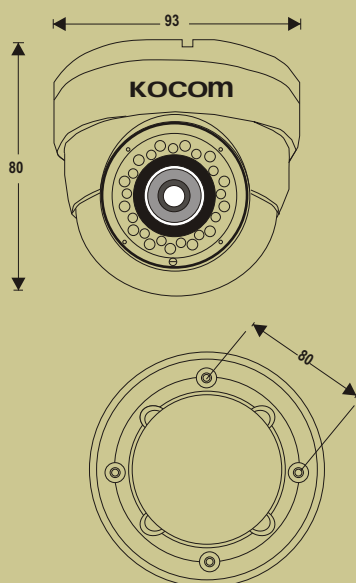

Dimensions



Specifications

Model Number	DS-IRVP400F
Image Sensor Device	1/3" Colour Sony Super HAD CCD
Total Pixels (PAL)	795(H) x 596(V)
Effective Pixels (PAL)	752(H) x 582(V)
Scanning Frequency (PAL)	15.625KHz(V), 50Hz(H)
Scanning System	2:1 Interlace
S/N Ratio	More than 48dB (AGC Off)
Horizontal Resolution	
DAY	480TV Lines
NIGHT	520TV Lines
Shutter Speed (PAL)	1/50~1/100,000 sec
Minimum Illumination	0.005 Lux (LED on)
Sync System	Internal
Video Output	VBS 1.0V p-p Composite (75)
Visibility Range	24 Unit infrared LED (850nm): 15m
Lens	F:6mm @ F2.0 Fixed Board Lens
White Balance	Automatic white balance
Video Output Jack	BNC connector
Power Input Jack	5.5 Jack
Power Consumption	DC12V±2V (Max. 1.7W, 4.8W with IR LED)
Operating Temperature	-10°~60°
Humidity	Within 90% RH
Material	Aluminum
Dome Size	93
Weight (Approx.)	0.6 kg